

## Installation Instructions

<b>CONTENTS:</b>	(2) H-402 LEFT BRACKET	(8) H-012 5/16" LOCK WASHER
	(2) H-403 RIGHT BRACKET	(8) H-030 5/16" HEX NUT
	(8) H-063 5/16-18 x 1-1/4" HEX BOLT	(8) H-074 M10 S.H.C.S.
	(16) H-011 5/16" FLAT WASHER	(8) H-038 3/8" LOCK WASHER
		(8) H-037 3/8" FLAT WASHER

1. Driver side, Install the supplied M10-1.25 bolts through a lock washer, flat washer, H-402 mounting brackets and into the factory tapped holes on the frame. Snug by hand.
2. Bolt the tube to the mounting brackets with four 5/16-18 hex bolts, lock washers, flat washers and 5/16-18 hex nuts. Snug the bolts, then check the alignment of the tube against the rocker panel.
3. Make any necessary adjustments, then tighten M10 bolts to 20 ft/lbs and 5/16-18 fasteners to 12 ft lbs. each.
4. Repeat steps on opposite side of vehicle.

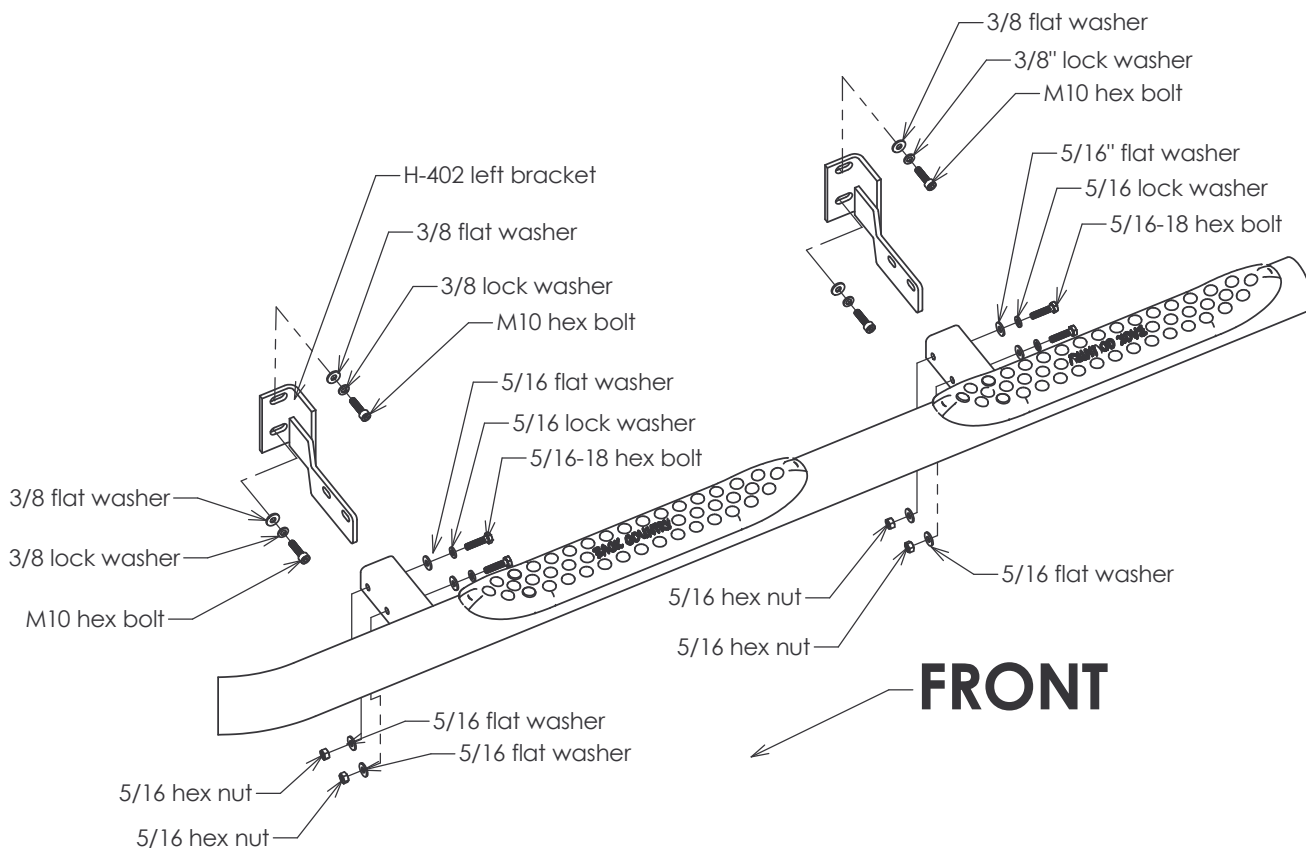

Rev. A 1/21/04