

Installation Instructions

CONTENTS:	(2) Step Tubes	(2) Front mount brackets
	(2) Rear mount brackets	(4) M12-1.75 x 120mm hex bolts
	(4) 1/2-13 x 2" hex bolts	(8) 1/2" flat washers
	(8) 1/2" lock washers	

1. Remove the factory bolts in the front and rear body mounts that go up into the truck cab.
2. Install the supplied M12-1.75 x 120mm bolts through a lock washer, flat washer, mount bracket and into the body mount. The mount bracket with the parking brake cable recess goes in the rear. Snug the bolts, but do not tighten at this time.
3. Bolt the tube to the brackets with two 1/2-13 x 2" hex bolts, lock washers and flat washers. Snugly tighten the bolts, then check the alignment of the tube against the rocker panel. Make any necessary adjustments, then tighten M12 fasteners to 45 ft lbs. and 1/2-13 bolts to 50 ft lbs.
4. Repeat steps on opposite side of the vehicle.

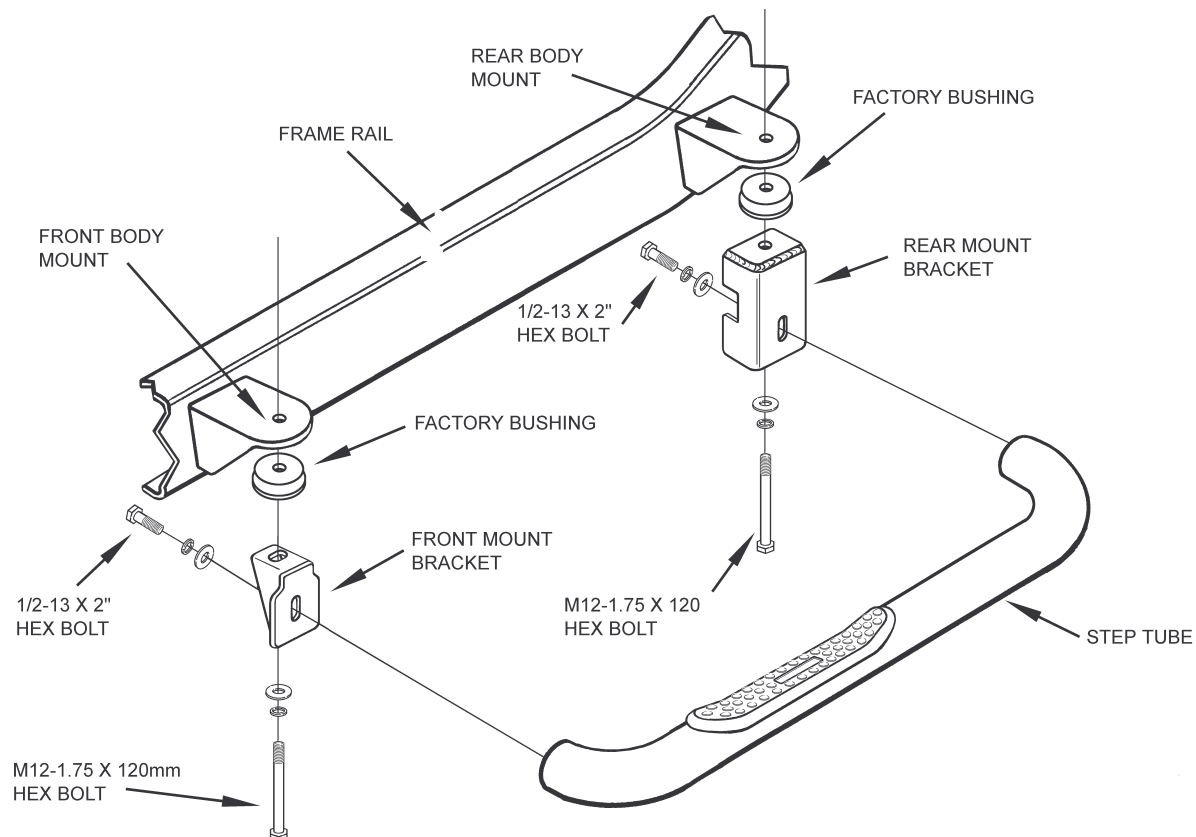

7049 1994-2004 Chevrolet-GMC S10-S15 Standard Cab Pickup

Back Country, Tekstyle and Teksport are Registered Trademarks of Design Automotive Group, Inc. All rights reserved