

## Installation Instructions

<b>CONTENTS:</b>	(2) Step Tubes	(2) Front mount brackets
	(2) Rear mount brackets	(4) M12-1.75 x 120mm hex bolts
	(4) 1/2-13 x 2" hex bolts	(8) 1/2" flat washers
	(8) 1/2" lock washers	

1. Remove the factory bolts in the front and rear body mounts that go up into the truck cab.
2. Install the supplied M12-1.75 x 120mm bolts through a lock washer, flat washer, mount bracket and into the body mount. The bracket with the brake cable recess goes in the rear. Snug the bolts, but do not tighten at this time.
3. Bolt the tube to the brackets with two 1/2-13 x 2" hex bolts, lock washers and flat washers. Snugly tighten the bolts, then check the alignment of the tube against the rocker panel. Make any necessary adjustments, then tighten M12 fasteners to 45 ft lbs. and 1/2-13 bolts to 50 ft lbs.
4. Repeat steps on opposite side of the vehicle.

Note: make sure the parking brake cable is routed properly and does not contact the rear bracket.

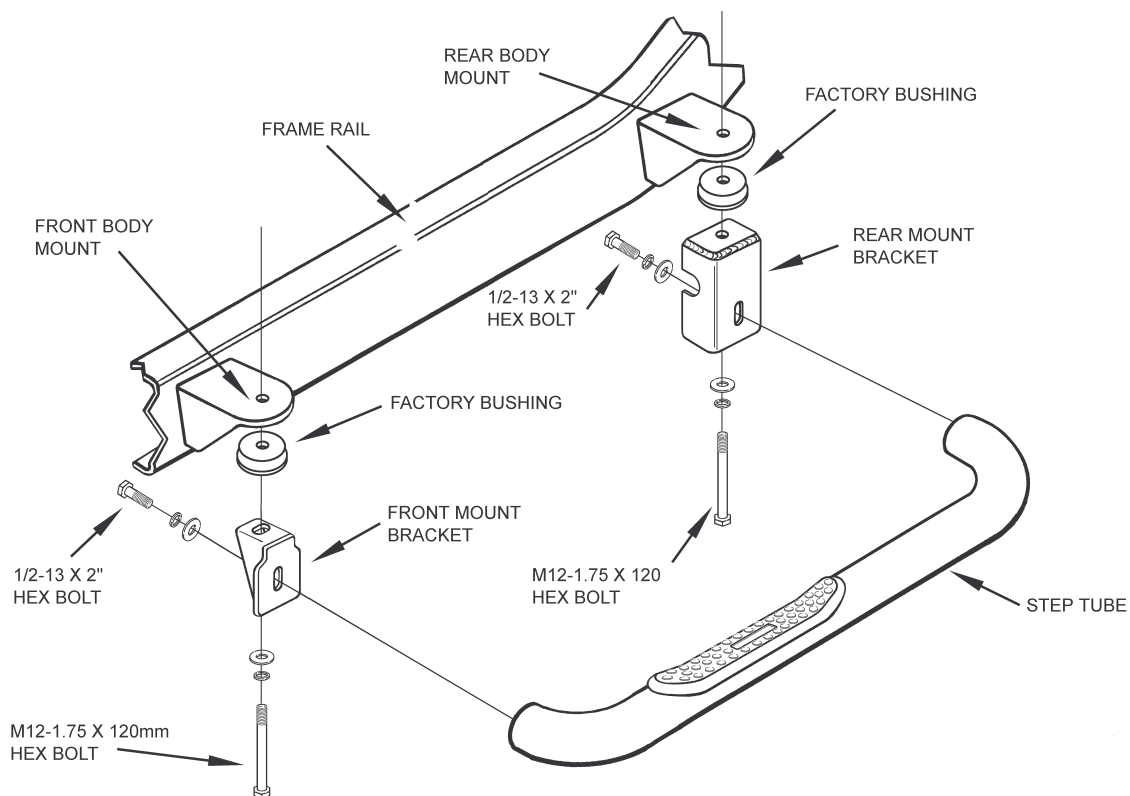

### 7051 1988-98 CHEVROLET/GMC FULLSIZE STANDARD CAB PICKUP

Back Country, Tekstyle and Teksport are Registered Trademarks of Design Automotive Group, Inc. All rights reserved