

BACK COUNTRY[®] Super Duty Super Cab 7082

CONTENTS: (2) Step Tubes	(2) Box mount brackets	(1) Left front lower bracket
(1) Right front lower bracket	(1) Left rear bracket	(1) Right rear brackets
(6) U-clip nuts	(2) 1/2-13 x 2" hex bolts	(2) 1/2" flat washers
(2) 1/2" lock washers	(24) 5/16-18 x 1 1/4" hex bolts	(42) 5/16 flat washers
(24) 5/16 lock washers	(18) 5/16-18 hex nuts	

1. Install the three U-clip nuts by sliding them into the rectangular openings at the frontmost and rearmost bracket locations on the back side of the rocker panel. These bracket locations can be identified by a small rectangular opening surrounded by 3-4 round holes. Use two U-clips nuts at the rear, and one in the front. Make sure threaded side of the U-clip nut is inside the rocker panel.
2. Secure the box mount bracket to the front location with a 5/16-18 x 1 1/4" hex bolt, lock washer, and flat washer at each U-clip nut. At the bottom, use a 5/16-18 x 1 1/4" hex bolt, two flat washers, one lock washer, and one 5/16-18 hex nut for each hole location that goes through the pinch weld. Make sure box bracket is offset toward the bottom (it should hang down approx. 1/2" from bottom of pinch weld). The head of the bolts should face the outside of the truck.
3. Secure the rear bracket to the rocker area with a 5/16-18 x 1 1/4" hex bolt, lock washer, and flat washer at each U-clip nut. At the bottom, use a 5/16-18 x 1 1/4" hex bolt, two flat washers, one lock washer, and one 5/16-18 hex nut for each hole location that goes through the pinch weld.
4. Next, install the front lower bracket with three 5/16-18 x 1 1/4" hex bolts, six 5/16 flat washers, three 5/16 lock washers, and three 5/16 hex nuts each. The flanged side of the bracket will face the center of the vehicle. Leave lower brackets loose enough to adjust the tube later.
5. Bolt the tube to the brackets with a 1/2-13 x 2" hex bolt, lock washer and flat washer at the front, and two 5/16-18 x 1 1/4" hex bolts, four 5/16 flat washers, two 5/16 lock washers, and two 5/16-18 hex nuts at the rear. Align tube, then tighten all bolts, torque 5/16-18 bolts to 8-12 ft lbs. and 1/2-13 bolts to 50 ft lbs.
6. Repeat steps on opposite side of the vehicle.

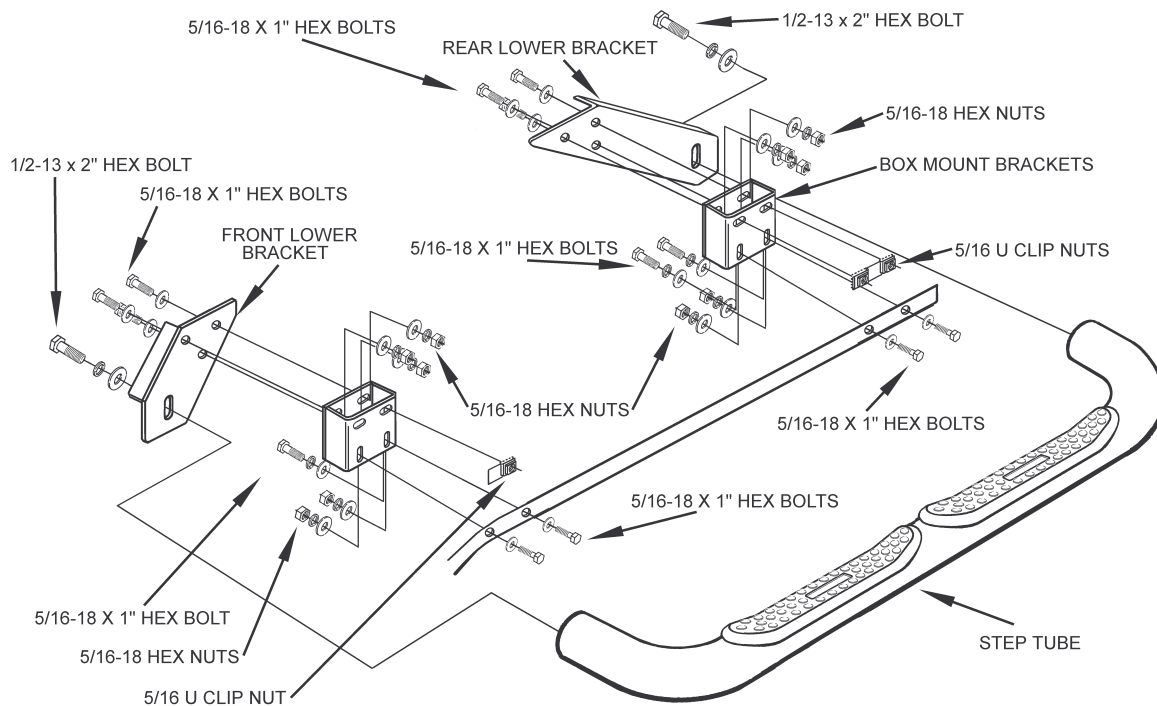

Rev A 1/26/06