

Installation Instructions

CONTENTS: (2) Step Tubes	(1) Left front bracket H-304	(1) Right front bracket H-305
(2) Front straps H-306	(1) Left rear bracket H-307	(1) Right rear bracket H-308
(2) Rear straps H-309	(4) Stud plates H-310	(2) Plates H-054
(4) 1/2-13 x 2" hex bolts	(4) 1/2-13 x 1 1/2" hex bolts	(12) 1/2" flat washers
(8) 1/2" lock washers	(4) 1/2-13 hex nuts	(8) 3/8" hex nuts
(8) 3/8" lock washers	(8) 3/8" flat washers	

1. Remove the two factory rubber grommets in the door sill area.
2. Install the front and rear stud plates into the oval cavities where the grommets were. Slide the mount brackets over the protruding studs and secure each with two 3/8 flat washers, two lock washers and two 3/8-16 hex nuts. Finger tighten at this time.
3. Mount the front support strap at the top using the existing hole and a 1/2-13 x 1 1/2" hex bolt, two 1/2" flat washers, a 1/2" lock washer and a 1/2-13 hex nut.
4. Mount the rear support strap at the top using the existing hole, an H-054 plate, 1/2-13 x 1 1/2" hex bolt, two 1/2" flat washers, a 1/2" lock washer and a 1/2-13 hex nut. First put the plate in place, through the cavity in the side, then drop the bolt (with flat washer) through the plate so the thread protrudes downward then secure strap with the washers and nut.
5. Bolt the tube through the straps and brackets with two 1/2-13 x 2" hex bolts, lock washers and flat washers. Finger tighten the bolts, then check the alignment of the tube against the rocker panel. Make any necessary adjustments, then tighten 3/8-16 fasteners to 20 ft lbs. and 1/2-13 bolts to 50 ft lbs.
6. Repeat steps on opposite side of the vehicle.

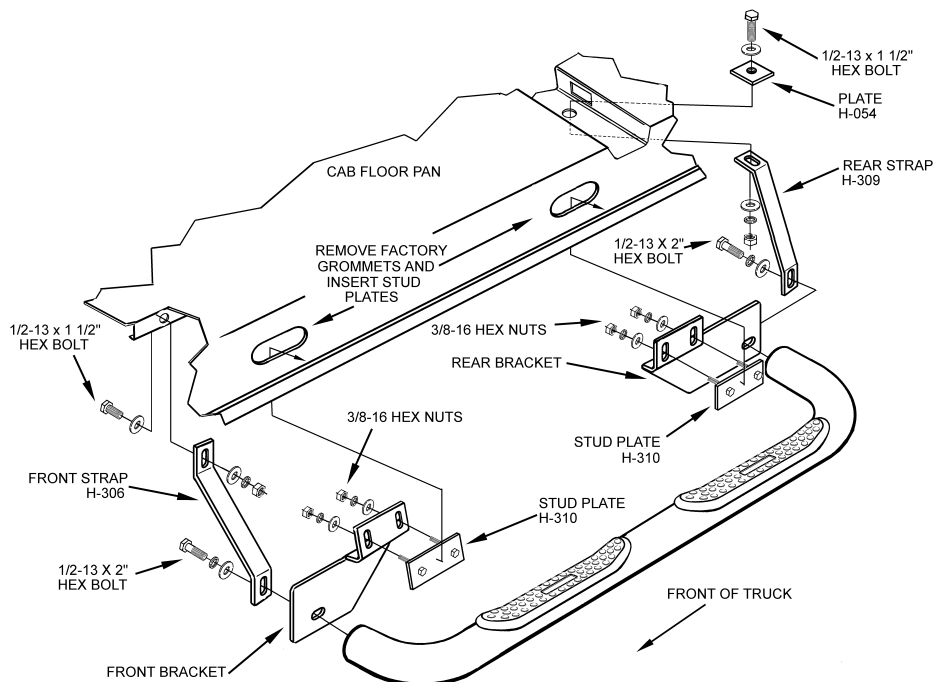

FORD F150 / 250 1999-03 4 DOOR PICKUP