

Installation Instructions

CONTENTS:	(2) Step Tubes 8091R, 8091L	(2) Front mount brackets H-200
	(1) Left rear mount bracket H-270	(1) Right rear mount bracket H-271
	(4) M12-1.75 x 120mm hex bolts	(4) 1/2-13 x 2" hex bolts
	(8) 1/2" flat washers	(8) 1/2" lock washers

1. Remove the factory bolts in the front and rear body mounts that go up into the truck cab.
2. Install the supplied M12-1.75 x 120mm bolts through a lock washer, flat washer, mount bracket and into the body mount. The mount bracket with the parking brake cable recess goes in the drivers side rear. Snug the bolts, but do not tighten at this time.
3. Bolt the tube to the brackets with two 1/2-13 x 2" hex bolts, lock washers and flat washers. Snugly tighten the bolts, then check the alignment of the tube against the rocker panel. Make any necessary adjustments, then tighten M12 fasteners to 45 ft lbs. and 1/2-13 bolts to 50 ft lbs.
4. Repeat steps on opposite side of the vehicle.

Note: make sure the parking brake cable is routed properly and does not contact the rear bracket.

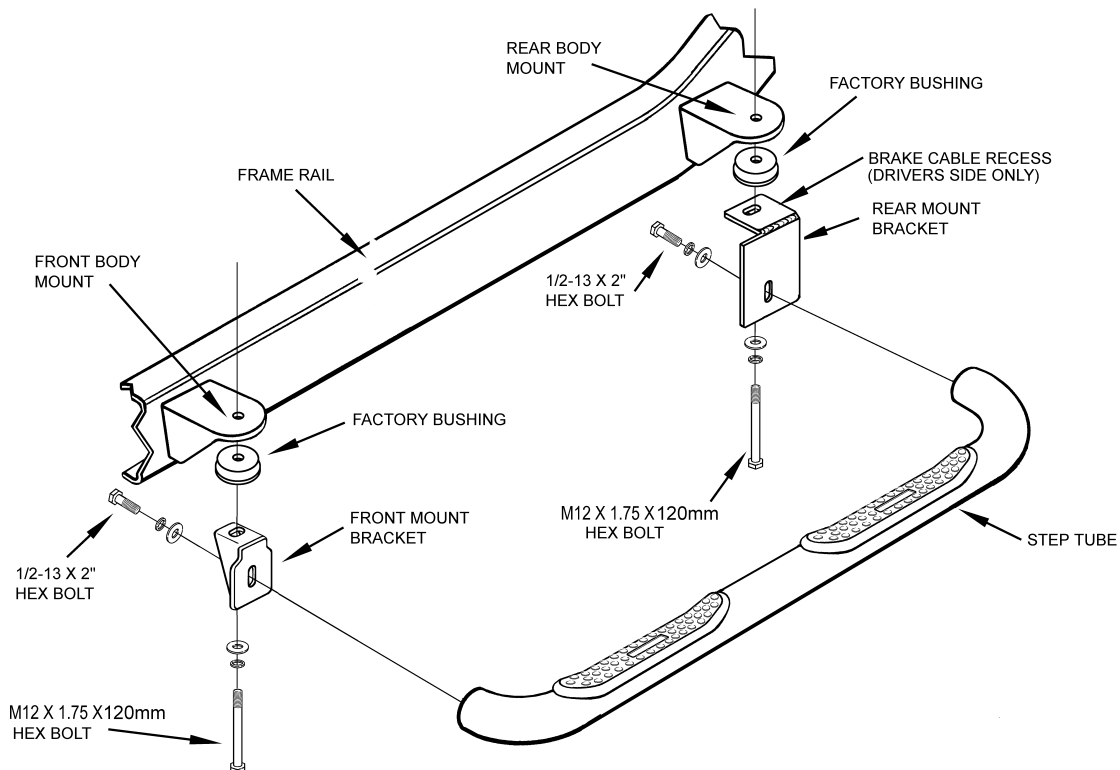

8091 1992-1998 Chevrolet-GMC Fullsize Crew Cab Pickup