

# Installation Instructions

### CONTENTS:

(2) Step Tubes (Drv & Pass)	(12) U-Clip Nuts (5/16-18)	(12) 5/16-18 x 1-1/4" Hex Bolts
(2) H-642 LF & RR Bracket	(8) 3/8-16 x 1" Hex Bolts	(12) 5/16" Lock Washers
(2) H-643 LR & RF Bracket	(8) 3/8" Lock Washers	(12) 5/16" Flat Washers
	(8) 3/8" Flat Washers	

1. Begin by locating the small rectangular openings (surrounded by round holes) at farthest front and farthest rear factory step locations. Install the 5/16-18 U-clip nuts at these locations (1 front and 1 rear). Affix the other four U-clip nuts over the pinch weld at the front two and rear two factory holes.

2. Using 5/16" hex bolts, lock washers and flat washers, install front and rear mounting brackets. Leave hardware finger tight.

3. Using 3/8" hex bolts and lock washers install step tube to the cradle of the mounting brackets. Leave hardware finger tight.

4. After aligning step tube straight and level with vehicle, torque 5/18" bolts to 20 ft lb and 3/8" bolts to 30 ft lbs.

5. Repeat above steps on opposite side.

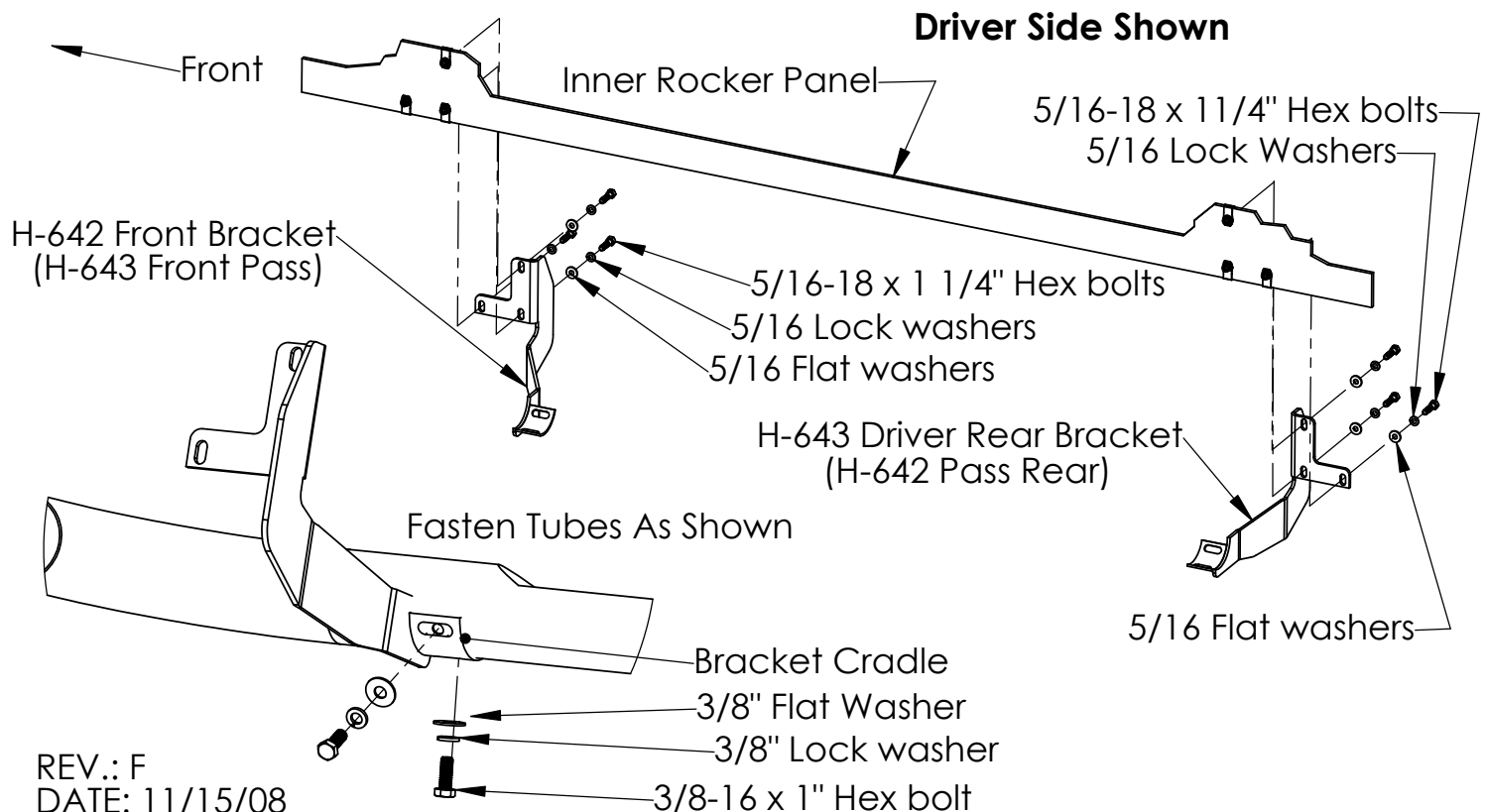

REV.: F  
DATE: 11/15/08

**\*\* This product is not intended to provide protection for the vehicle or the occupants within \*\***

Back Country, Tekstyle and Teksport are Registered Trademarks of Design Automotive Group, Inc. All rights reserved